

## Precision Calibrator

### FEATURES

- Portable, on-site calibration and servicing—accurate to 0.02% of selected range
- Eight selectable ranges: 0, 0.5, 1.0, 1.5, 2.0, 2.5, 3.0, and 3.5 mV/V
- Three bridge impedance selections: 350, 700, or 1000  $\Omega$
- Calibrate any strain gage based instrument or transmitter
- Rugged, impact resistant aluminum case

### APPLICATIONS

- Testing, calibrating, and troubleshooting process weigh system instrumentation

### DESCRIPTION

The Model 325 precision calibrator supplies high accuracy millivolt-per-volt level signals for testing, calibrating, and troubleshooting process weigh system instrumentation. Precise output reference selections from 0 to 3.5 mV/V are achieved by using a metal film resistor network, discrete wire wound resistors, and a 2-pole, 8-position rotary switch. Input and output impedance values of 350, 700, and 1000  $\Omega$  are selectable to simulate all typical strain gage transducers. Four permanent binding posts, integral to the rugged aluminum case, provide connection points for the instrument or transmitter.



A built-in vernier adjustment provides a mV/V output signal from 0 to 106% of the selected range. Full range simulation tests setpoint cutoffs, auto-tare, auto-zero, overload, and other crucial instrument functions without loading the system.

The Model 325 unit substitutes for single or multiple system transducers. Lightweight construction, compact size, and superior accuracy make the Model 325 calibrator an excellent choice for calibrating, spot-checking, or trouble shooting weigh systems in any environment.

### SPECIFICATIONS

PARAMETER	VALUE
<b>PERFORMANCE</b>	
Output Accuracy	0.02% of selected range
Accuracy Stability (0.5 and 1 mV/V steps)	less than 0.01% in 24 hours less than 0.02% in 1 year
Zero Stability	less than 3 $\mu$ V
Span TC	$\pm$ 10 ppm/ $^{\circ}$ C
Input Impedance (Excit.)	adjustable to $\pm$ 0.05%
Output Impedance (Signal)	adjustable to $\pm$ 0.08%
Output Ranges	8 steps: 0, 0.5, 1.0, 1.5, 2.0, 2.5, 3.0, and 3.5 mV/V

PARAMETER	VALUE
Input Voltage Level	25 VDC maximum
Operating Temperature Range	32 $^{\circ}$ F to 120 $^{\circ}$ F (0 $^{\circ}$ C to 50 $^{\circ}$ C)
Vernier Range	up to 106% of selected step
Impedance Adjustmen	350, 700, or 1000 $\Omega$
<b>MECHANICAL</b>	
Dimensions, LxWxH	6 $\times$ 3.2 $\times$ 1.8 in.
Unit Weight	15.7 oz

Precision Calibrator

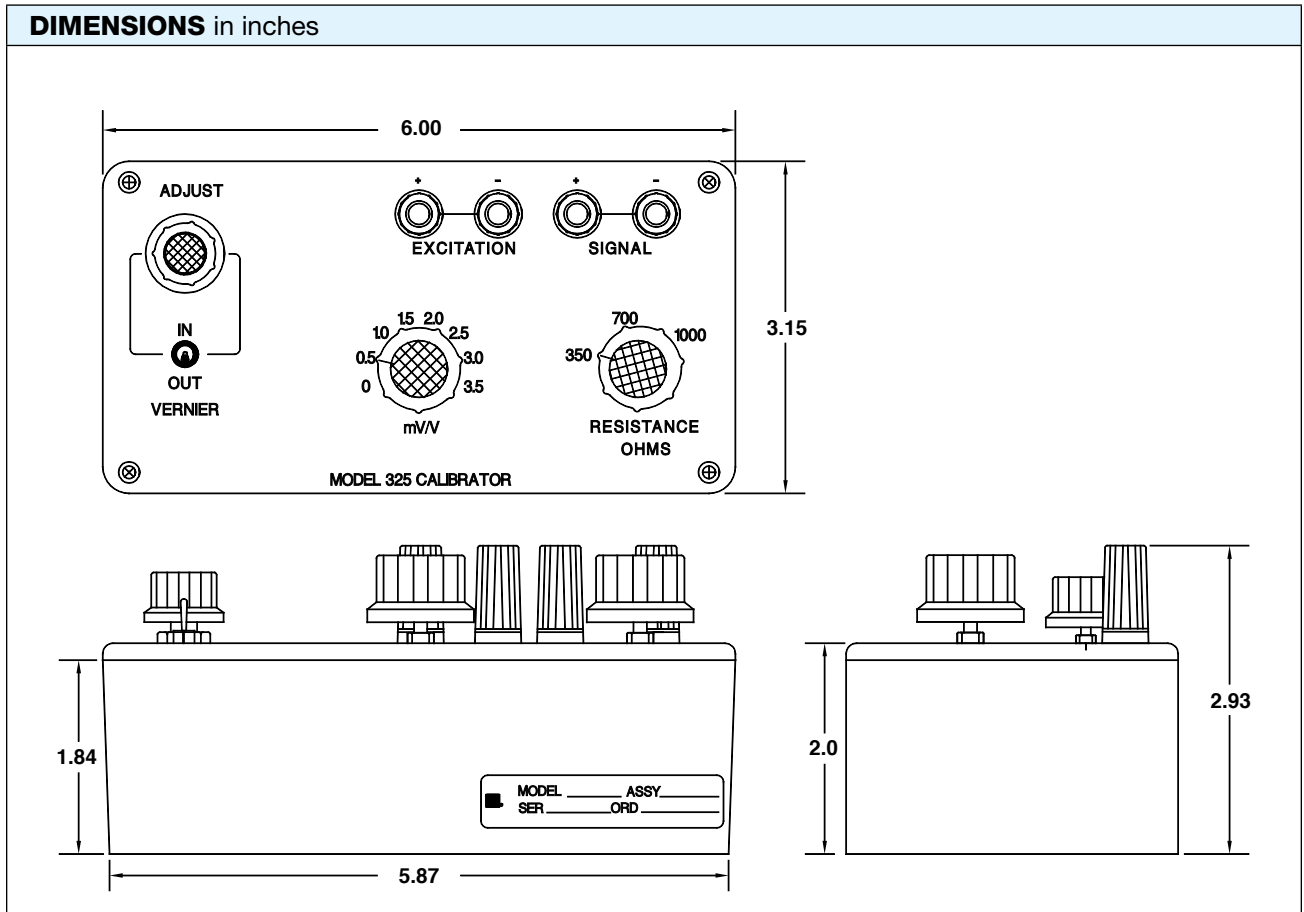

BLH Nobel is continually seeking to improve product quality and performance. Specifications may change accordingly.