

Web Tension Measurement Module

FEATURES

- Full Wheatstone bridge construction with temperature-compensated, Micro-Measurements SR-4® foil strain gages
- Easy retrofit with existing machine pillow blocks
- 100% stainless steel construction
- IP67/NEMA 4 environmental sealing
- Factory calibration eliminates need for on-site test weights

APPLICATIONS

- Asphalt shingle production equipment
- Paper and converting machinery
- Suitable for applications in harsh, hot environments
- Perfect for 180° wrap angle applications

DESCRIPTION

HTK Web Tension Measurement Modules are designed to measure vertical forces in the up or down direction and mount directly below roller pillow blocks in new or existing installations. Each module includes an integral top and bottom adapter plate with hole mounting arrangements for typical installations found in the roofing, converting, printing, and plastic industries. The design also provides safety stop installation points at each corner.

Transducer and mounting hardware components are 100% stainless steel for use in harsh, industrial environments. Module sealing meets NEMA 4 and IP67 requirements. An integral cable conduit fitting and epoxy sealed strain gages ensure long-term reliability in wet or washdown locations.

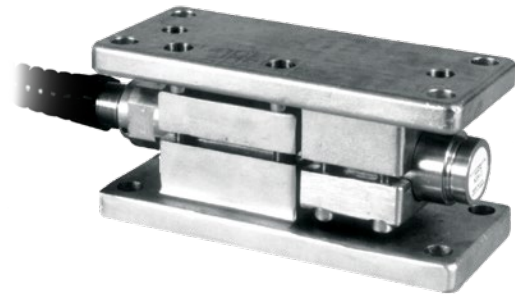

A full Wheatstone bridge array of temperature compensated, Micro-Measurements SR-4 strain gages are bonded to the 'I' beam type sensing section and factory calibrated for precision accuracy. Resulting temperature stability is due to closely matching the expansion coefficient of the sensing section to patented SR-4 gages.

Space required below the pillow block bearing is minimal, resulting in negligible line profile changes on retrofit installations. Overall module height is only 3.27 in. Low profile, along with rated capacities of 0.5, 1, 2, and 5 kN, permits direct replacement of other type load cells.

Modules are calibrated and certified with matched output signals to permit on-site, push-button system calibration.

CONFIGURATION

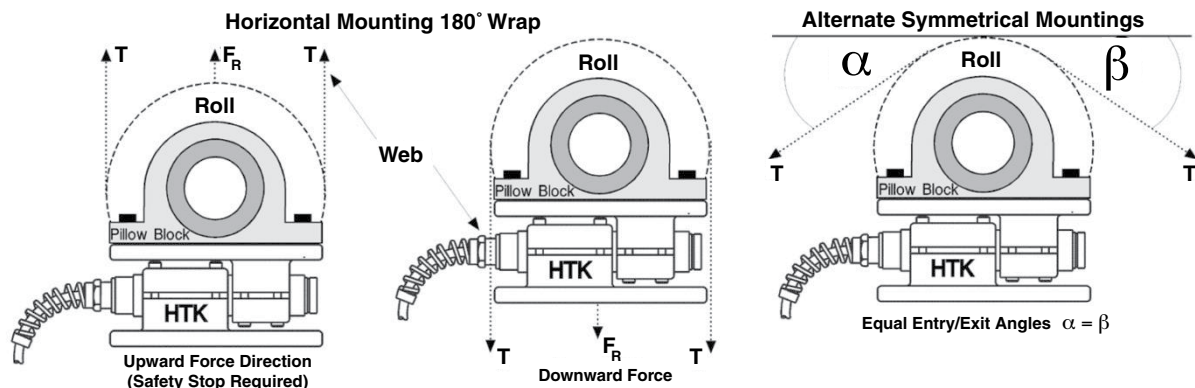

Web Tension Measurement Module

THE DOUBLE CANTILEVER ADVANTAGE

Double cantilever shear beams measure the shear force without errors caused by changing point or moment stresses.

The HTK Web Tension Module incorporates an outer sleeve that can be thought of as a second cantilever, rigidly attached to the free end of the first cantilever. Thus the term double cantilever. With this design, the applied force is brought back to a point directly over the gaged area. A cross section shaped as an 'I' BEAM provides the desired shearing stress while maintaining a high degree of rigidity against bending in all directions. The second cantilever also is effective at isolating load application point stresses from the active element.

Double cantilever shear beams approach the ideal in tension transducer design: they measure the desired force while ignoring any extraneous forces that may be present.

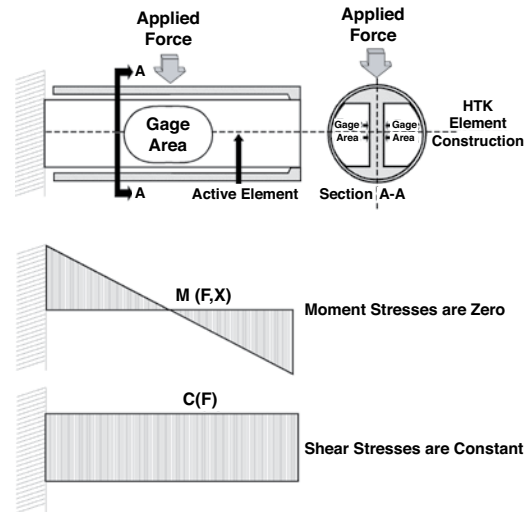

OUTLINE DIMENSIONS

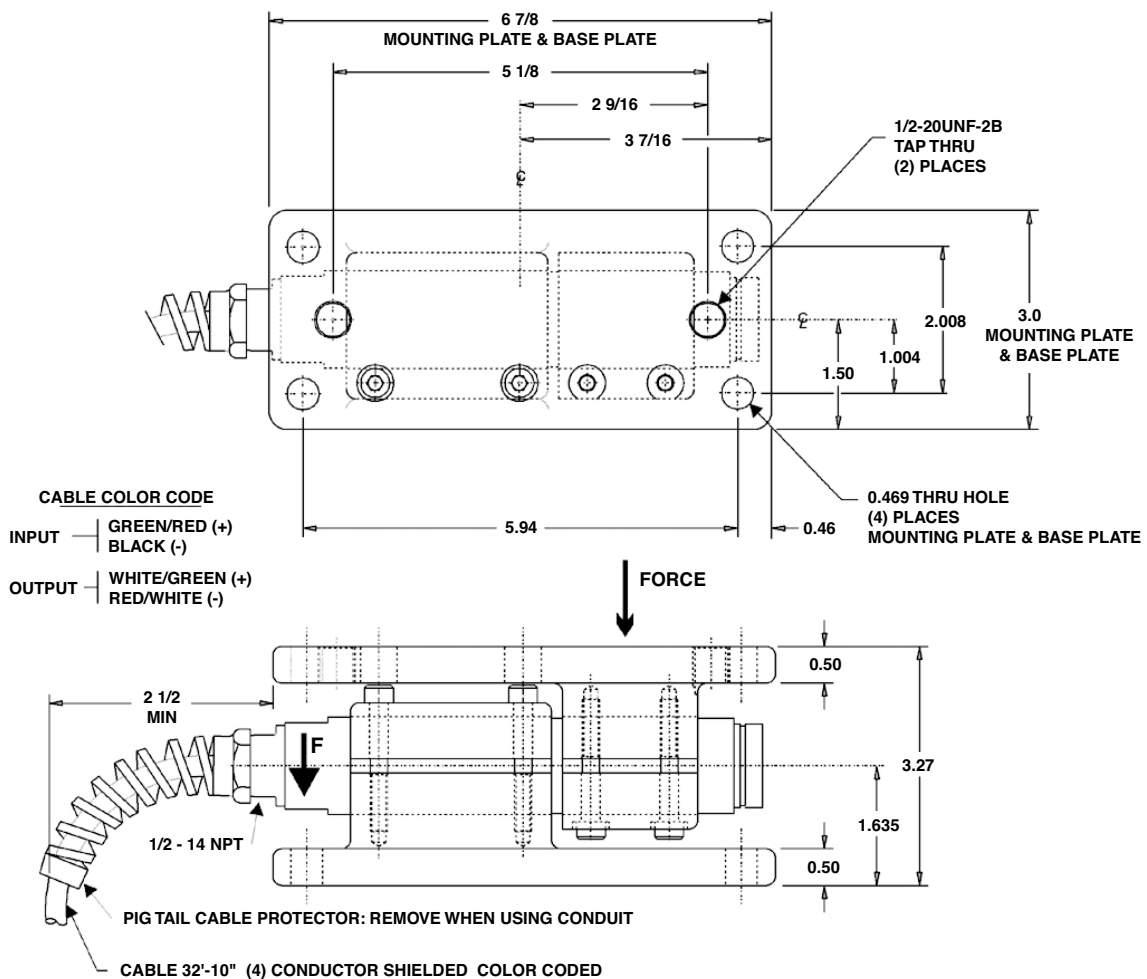

Web Tension Measurement Module

TYPICAL SYSTEM CONFIGURATIONS

BASIC WEB TENSION SYSTEM WITH SYMMETRICAL WRAP ANGLES

- Analog summing of both ends of roll
- 3½ digit display of total tension
- 4–20 mA and 0–10 V analog output to web tension controller
- RS-485 serial output to computer
- Allen-Bradley Remote I/O Interface to PLC

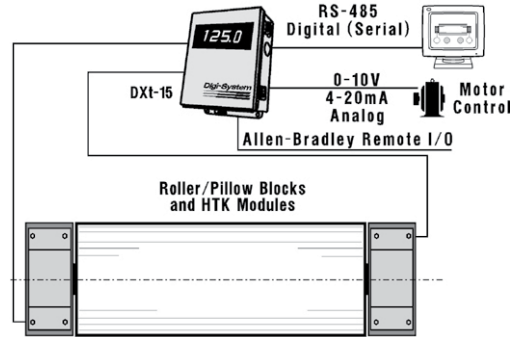

'EXPERT' SERIES WEB TENSION SYSTEM

- Continuous display of left, right, or total tension
- Keypad calibration eliminates need for on-site test weights
- Individually digitized transducer data
- Continuous 'Expert System' diagnostics
- Dynamic digital filter
- 750,000 count resolution per channel; 20 updates per second
- Multiple analog outputs
- Display units = pli, lb, kg, N, and N/m
- Allen-Bradley Remote I/O or Modbus Plus Interface to PLC

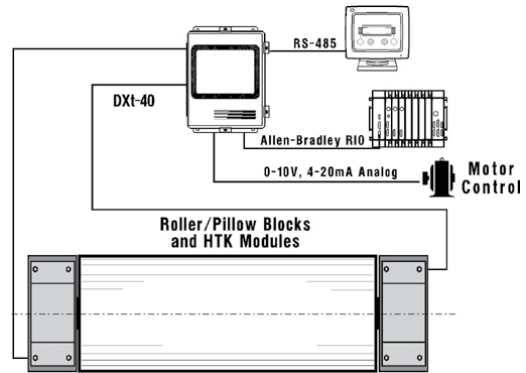

AVAILABLE INSTRUMENTATION

LCt-104



Multi-Zone
Tension
Transmitter

DXt-40



Tension
Display Left,
Right or Total

AST 3P



High
Resolution Tension
Transmitter

PS-2010T



DIN Rail Mount

Web Tension Measurement Module

SPECIFICATIONS		PARAMETER	VALUE
PERFORMANCE		PARAMETER	VALUE
Capacity	0.5 kN–5 kN (112.5–1125 lb)*	ELECTRICAL	
Rated output (RO)	2.0394 mV/V \pm 0.25%	Excitation voltage	10 VAC-VDC recommended, 20 VAC-VDC maximum
Zero balance	5.0% RO	Input resistance	350 \pm 3.0 Ω
Error Max. – % RO	0.15 for 0.5 kN capacity 0.05 (combined error, best fit through zero)	Output resistance	350 \pm 3.0 Ω
Creep (5 minutes)	\pm 0.03% RO	Insulation resistance	4 G Ω minimum
Repeatability	0.01% rated capacity	Connection – 4-Cond. Cable	10 m (32 ft, 10 in)
TEMPERATURE		MATERIAL	
Compensated temperature	–1 to +54°C (+30 to +130°F)	Beam	Stainless Steel (15-5PH)
Safe temperature	–40 to +105°C (–40 to +220°F)	Moisture protection	IEC IP67
TEMPERATURE EFFECTS		Unit weight	12 lb—all capacities
Zero balance – %RO	0.0014/°C (0.008/°F)	DEFLECTION UNDER LOAD	
Output – % reading	0.0033/°C (0.0018/°F)	0.5 kN	0.101 mm (0.004 in)
OVERLOAD RATING – % RATED CAPACITY		1 kN	0.101 mm (0.004 in)
Safe load	150	2 kN	0.101 mm (0.004 in)
Ultimate load	300	5 kN	0.152 mm (0.006 in)
Safe sideload	100		
Ultimate sideload	200		

NOTE: 1 kN = approx. 225 lb

BLH Nobel is continually seeking to improve product quality and performance. Specifications may change accordingly.