

## ATEX-Approved Load Cell Transmitter with HART Communication

### FEATURES

- ATEX approved Ex IIC
- Two-wire 4 mA–20 mA output with error signaling
- HART 7 Communication for
  - System diagnostics
  - Process Data
- IP67 protection level (when mounted in load cell)
- M12 connector or fixed cable connection through cable gland



### APPLICATIONS

- Cranes
- Winches
- Mooring
- Chain stoppers
- Tension

### DESCRIPTION

Load cell transmitter for off-shore and harsh industrial applications. The transmitter is field-replaceable without re-calibration of the transmitter or the load cell. HART Communication is available for diagnostics and process data. The load cell transmitter is designed to be embedded in the load cells and is approved for use in hazardous areas.

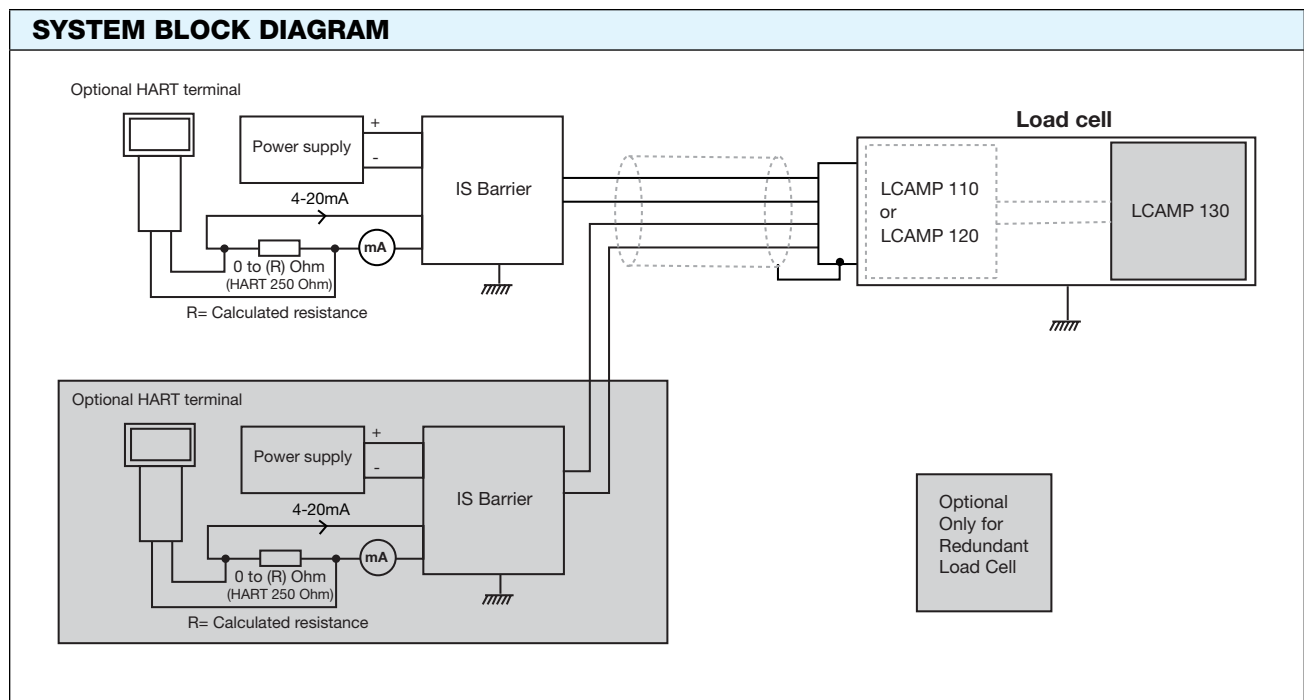

## ATEX-Approved Load Cell Transmitter with HART Communication

SPECIFICATIONS			
PARAMETER	VALUE		
<b>APPROVALS</b>			
<b>ATEX intrinsic safety</b>	EN 60079-0, EN 60079-11, EN 50303 Ex ia I Ma, Ex ia IIC T4 Ga, Ex ia IIIC T79°C Da		
<b>U<sub>i</sub></b>	30 V		
<b>P<sub>i</sub></b>	0.7 W		
<b>I<sub>i</sub></b>	100 mA		
<b>C<sub>i</sub></b>	57 nF (≤66 nF including cable)		
<b>L<sub>i</sub></b>	4.4 μH		
<b>IECEx intrinsic safety</b>	IEC 60079-0, IEC 60079-11		
<b>Electromagnetic compatibility (EMC)</b>	EN 61326-1		
<b>Emission</b>	CISPR 11 class B		
<b>ENVIRONMENTAL CONDITIONS</b>			
PARAMETER	MIN.	TYP.	MAX.
<b>Environmental protection/ IP rating (assembled load cell)</b>		IP67	
<b>Operating Temperature (T<sub>amb</sub>)</b>	-45°C -49°F		+70°C +158°F
<b>In intrinsic-safe application (T<sub>amb</sub>)</b>	-45°C -49°F		+70°C +158°F
<b>ANALOG OUTPUT</b>			
<b>Current</b>	3.2 mA		22.8 mA
<b>Rated output (RO)</b>		20 mA	
<b>Zero</b>		4 mA	
<b>SYSTEM PARAMETERS</b>			
<b>Accuracy</b>	See load cell datasheet		
<b>Response time: Fast mode</b>		5 ms	
<b>Response time: HART® compliant mode</b>		50 ms	
<b>Noise: Fast mode</b>		0.05% of RO	
<b>Noise: HART® compliant mode</b>		0.02% of RO	
<b>Supply voltage (E): Standard application</b>	E = 0.0236*R+10.5 V	24 V	42 V
<b>Supply voltage (E): Intrinsic-safe application</b>		24 V	30 V
<b>Load impedance (R): Standard application</b>	0 Ω		R = (E-10.5)/0.0236 Ω (HART max. 600 Ω)
<b>Load impedance (R): HART® communication</b>	230 Ω	250 Ω	
<b>Insulation resistance</b>	4 GΩ		
<b>LOAD CELL STRAIN GAGE</b>			
<b>Impedance</b>		2000 Ω	
<b>ATEX CONDITIONS</b>			
<b>Cable length (L) for Ex ia IIC</b>			L = 9.0/(nF/m) <sup>(1)</sup> m
<b>Cable length (L) for Ex ia IIB</b>			L = 503/(nF/m) <sup>(1)</sup> m
<b>Insulation test</b>		500 V <sub>RMS</sub>	
<b>CONNECTOR PIN-OUT / WIRES COLOR CODE</b>			
<b>M12 Connector</b> 1: LCAMP 130 current return 2: LCAMP 130 current output 3: LCAMP 110 current output 4: LCAMP 110 current return		<b>Fixed cable</b> Yellow: LCAMP 130 current return Green: LCAMP 130 current output White: LCAMP 120 current output Brown: LCAMP 120 current return	

<sup>(1)</sup> Cable capacitance value per meter in nF