

## Load Cell Weigh Module

### FEATURES

- Capacity range: 500, 1K, 2K, 5K, 10K, 20K, and 50K lb (227, 454, 907, 2.27K, 4.5K, 9K, and 22.7K kg)
- ‘Checkless’ design—no stay or check rods required
- Low profile and integral thermal expansion assembly simplifies installation
- Designed to meet ANSI/ASCE wind load and seismic requirements
- Double cantilever design improves system performance and accuracy
- FM and CSA approved

### APPLICATIONS

- Inventory silos
- Storage tanks
- Process vessels

### DESCRIPTION

Z-BLOK Weigh Modules are specifically designed to meet the requirements of inventory and process weighing applications. Checkless design (no stay or check rods), low profile, and uniform bolt spacing simplify installation on new or existing vessels. The integral expansion assembly, double cantilever design, and temperature compensated full bridge transducer, minimize temperature effects allowing accurate measurement indoors or out, in virtually any environment.

The ANSI/ASCE qualified design provides an efficient balance between performance as a transducer and strength as a structural member when earthquakes or wind resistance is a structural design requirement.

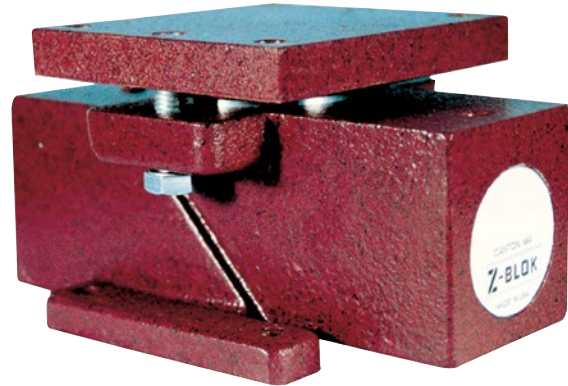

Sideloads of up to 100% full scale capacity, caused by mixer torque, vibration, or other extraneous forces, virtually have no effect on weight measurement.

An integral cable conduit fitting, sealed strain gages, and a stainless steel transducer ensure long life in wet or washdown locations. High overload capacity, ductile iron mounting hardware, and high strength assembly bolts enable the Z-BLOK to survive where others fail.

### CONFIGURATION

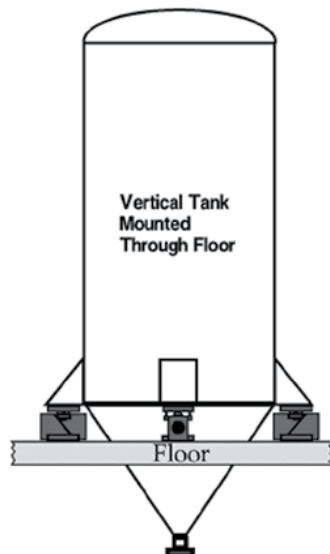

Load Cell Weigh Module

**THE DOUBLE CANTILEVER ADVANTAGE**

Double cantilever shear beams measure the shear component of force without errors caused by changing point or moment stresses.

The Z-BLOK Weigh Module incorporates an outer sleeve that can be thought of as a second cantilever, rigidly attached to the free end of the first cantilever. Thus the term double cantilever.

With this design, rather than applying force at the free end of the beam, the point of load application is brought back to a point directly over the gaged area. The result is that bending moment is close to zero across the gaged area. Because a shear beam is designed to measure shear, not bending, any reduction in bending moment stress is desirable. The second cantilever also is effective at isolating load application point stresses from the active element.

Reducing the force due to bending moment in a cantilever beam has a side benefit—a reduction in the beam’s strength requirements. By reducing the bending moment induced at the weakest part of the shear beam (section A-A), a double cantilever shear beam can be operated at a stress level well below that of a single cantilever shear beam. The result is a more conservative structural design with high overload capacity and fatigue resistance.

Double cantilever shear beams approach the ideal in load cell design; they measure the desired force while ignoring any extraneous forces that may be present.

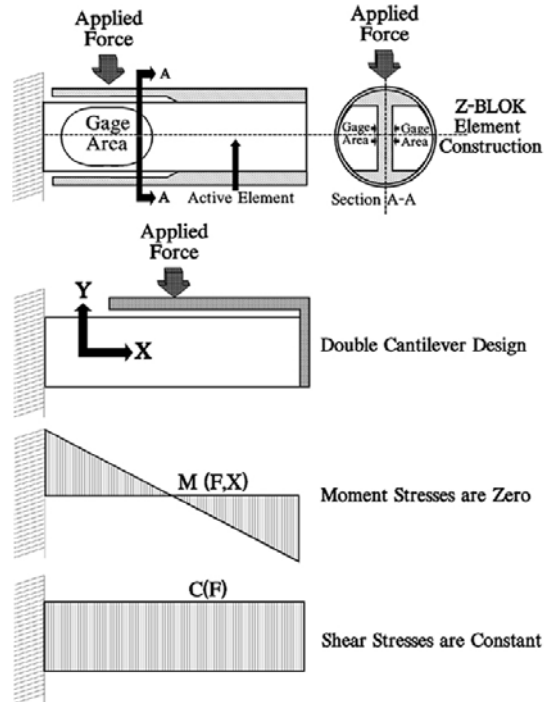

**THE INTEGRAL THERMAL EXPANSION/RETAINER PLATE ADVANTAGE**

Z-BLOK’s unique design incorporates an integral expansion/retainer plate assembly with retainer bolts. This mounting arrangement provides simple checkless installation while allowing for minor mounting surface irregularities and vessel/structure expansion and contraction. The spherical load button and socket eliminates torsional stresses on the load element caused by non-level or out of plumb mounting surfaces.

End load stresses, caused by vessel/structure expansion and contraction or process vibration, are negated by the teflon impregnated slide plate. The expansion/retainer plate assembly is attached to the module at the factory and requires no adjustments. The high strength bolts that connect the module and expansion/retainer plate assembly provide resistance to uplift forces and complete the checkless design.

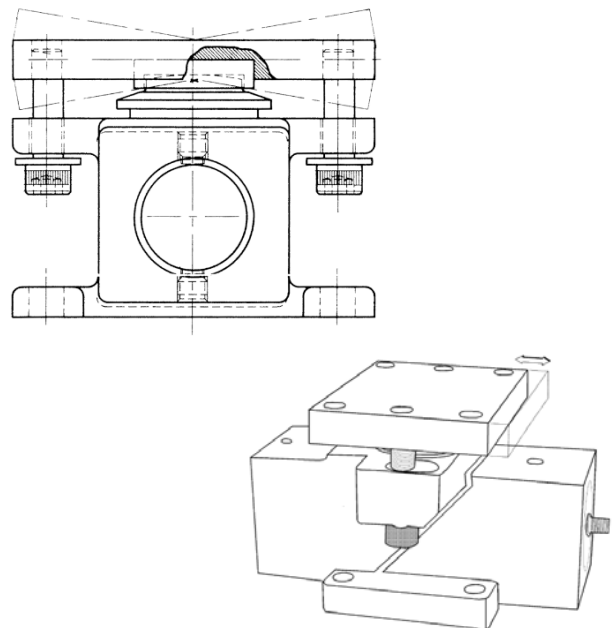

Load Cell Weigh Module

**OUTLINE DIMENSIONS**

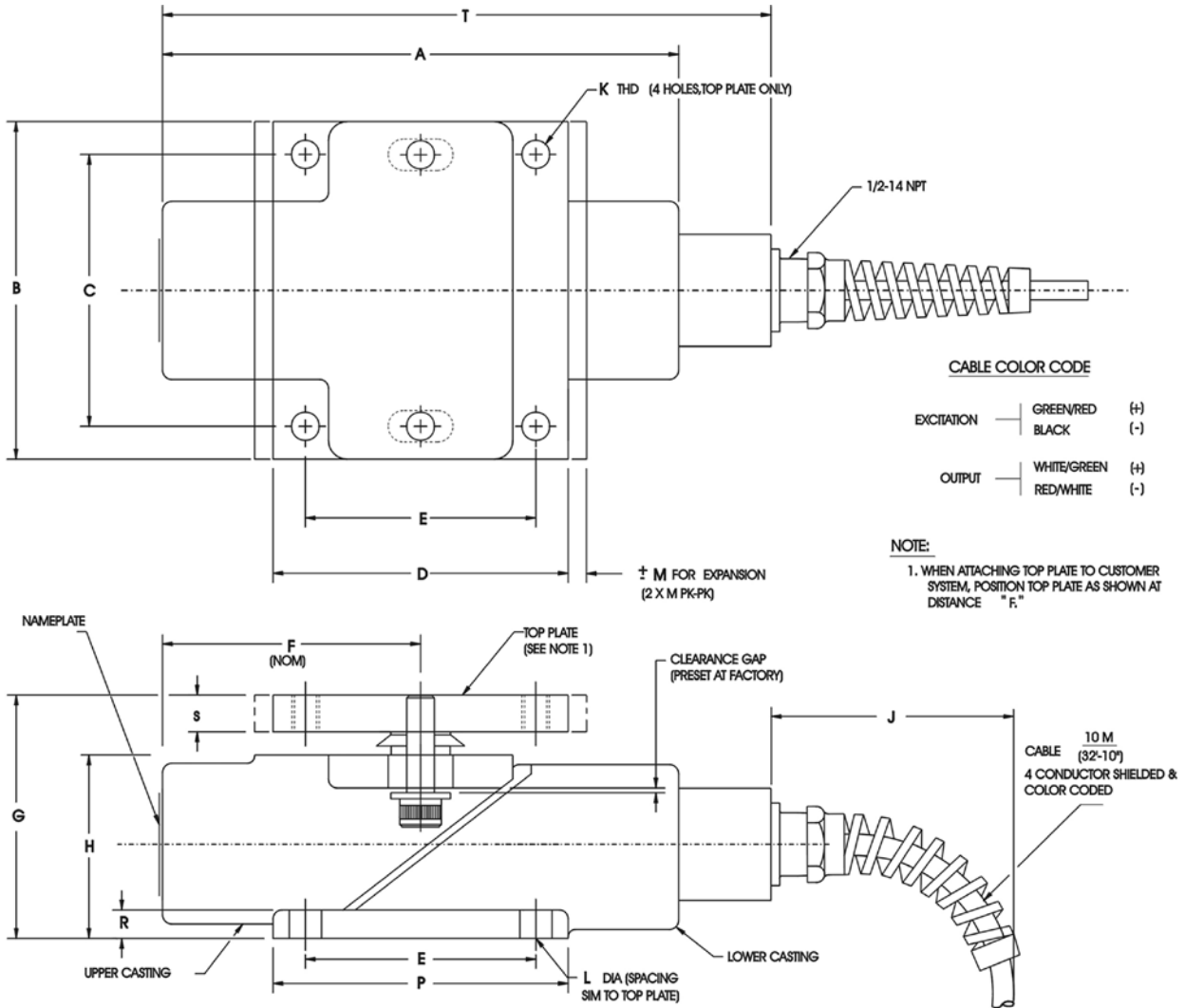

PART NO.	CAPACITY (lb)	A	B	C	D	E	F	G	H	J	K	L	M	P	R	S	T	
468530-4	500	152.4	98.4	76.2	88.9	65.0	76.2	68.3	50.5	76.2 (3)	1/4-20	8.13	2.2	89	7.9	9.1	190.5	
462795-4	1,000	(6.0)	(3.875)	(3.0)	(3.50)	(2.56)	(3.0)	(2.69)	(1.99)		3/8-16	10.9	4.0	101.6	9.7	12.4	209.6	
462796-4	2,000	177.8	114.3	91.95	101.6	79.2	88.9	88.1	63.2		76.2 (3)	1/2-13	10.9	4.5	127	14.2	18.5	—
462797-4	5,000	(7.0)	(4.50)	(3.62)	(4.0)	(3.12)	(3.50)	(3.47)	(2.49)			5/8-11	12.7	4.8	139.7	19.1	21.8	—
462798-4	10,000	228.6	139.7	112.3	127.0	99.6	114.3	115.6	85.3			3/4-10	17.5	6.3	165.1	25.4	24.9	—
462799-4	20,000	(10.0)	(6.38)	(5.06)	(5.50)	(4.18)	(5.0)	(5.39)	(3.92)				—	—	—	—	—	—
462800-4	50,000	305.1	190.5	152.4	177.8	127.0	152.4	177.3	126.5	—	—	—	—	—	—	—	—	

Dimensions shown in mm (inches)

## Load Cell Weigh Module

### SIMULATED WEIGH MODULES

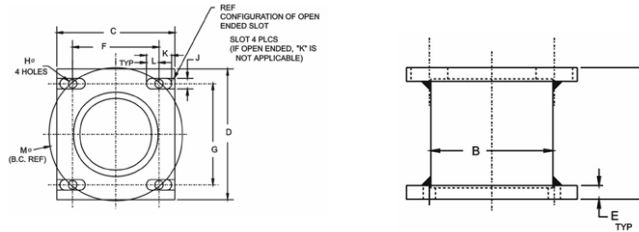

CAP. LB	A	B °	C	D	E	F	G	H °	J	K	L	M ° BC REF
500/1K	2.69	2 1/2	3 1/2	4.0	.50	2.560	3.000	5/16	5/16	3/4	3/8	3.944
2K & 5K	3.47	3 1/4	4	4 1/2	.50	3.120	3.620	7/16	7/16	—	7/16	4.779
10K	4.55	3 1/2	5	5 1/2	.63	3.920	4.420	7/16	9/16	—	1/2	5.908
20K	5.39	4	5 1/2	6 3/8	.75	4.180	5.060	1/2	11/16	—	9/16	6.563
50K	6.98	4 3/4	7	7 1/2	1.00	5.000	6.000	11/16	13/16	1 1/4	5/8	7.810

#### Thermal Insulation Pads

In applications where heat conduction is a concern, BLH Nobel can provide thermal pads to isolate the Z-BLOK modules from the hot vessel. The one inch thick, phenolic glass pads install directly between the Z-BLOK expansion/retainer plate and the vessel gusset/mounting bracket for thermal insulation.

### SPECIFICATIONS

PARAMETER	VALUE
<b>PERFORMANCE</b>	
Capacity	500, 1K, 2K, 5K, 10K, 20K, and 50K lb (227, 454, 907, 2.27K, 4.5K, 9K and 22.7K kg)
Rated output (RO)	2.0 mV/V ±0.1% mV/V,
Repeatability	0.01% RO
Combined error (best fit)	0.10% RO
Zero balance	5% RO
Creep (20 minutes)	0.03% RO
Temperature effects on zero balance	0.0017% RO/°F
Temperature effects on span	0.0020% Load/°F
<b>ELECTRICAL</b>	
Recommended excitation	10 VDC (15 VDC max.)
Input resistance	350 Ω ±3 Ω
Output resistance	350 Ω ±3 Ω
Cable length	32 ft, 10 in cable w. conduit fitting
<b>TEMPERATURE</b>	
Safe range	-40 to 220°F
Compensated range	+30 to 130°F

PARAMETER	VALUE	
<b>ADVERSE LOAD RATINGS</b>		
Safe load	150% rated capacity	
Safe sideload	100% rated capacity	
Safe uplift	50% rated capacity	
<b>MATERIAL</b>		
Beams	15-5PH Stainless Steel	
Brackets	painted* ductile iron	
<b>DEFLECTION AND UNIT WEIGHT</b>		
Capacity	Deflection	Weight
500 lb	0.012 in	10 lb
1K lb	0.012 in	10 lb
2K lb	0.013 in	15 lb
5K lb	0.027 in	15 lb
10K lb	0.023 in	35 lb
20K lb	0.047 in	50 lb
50K lb	0.066 in	75 lb

\*single component, waterborne polyurethane copolymer—high gloss

BLH Nobel is continually seeking to improve product quality and performance. Specifications may change accordingly.